

K1. かま関係 / Rotary hook mechanism

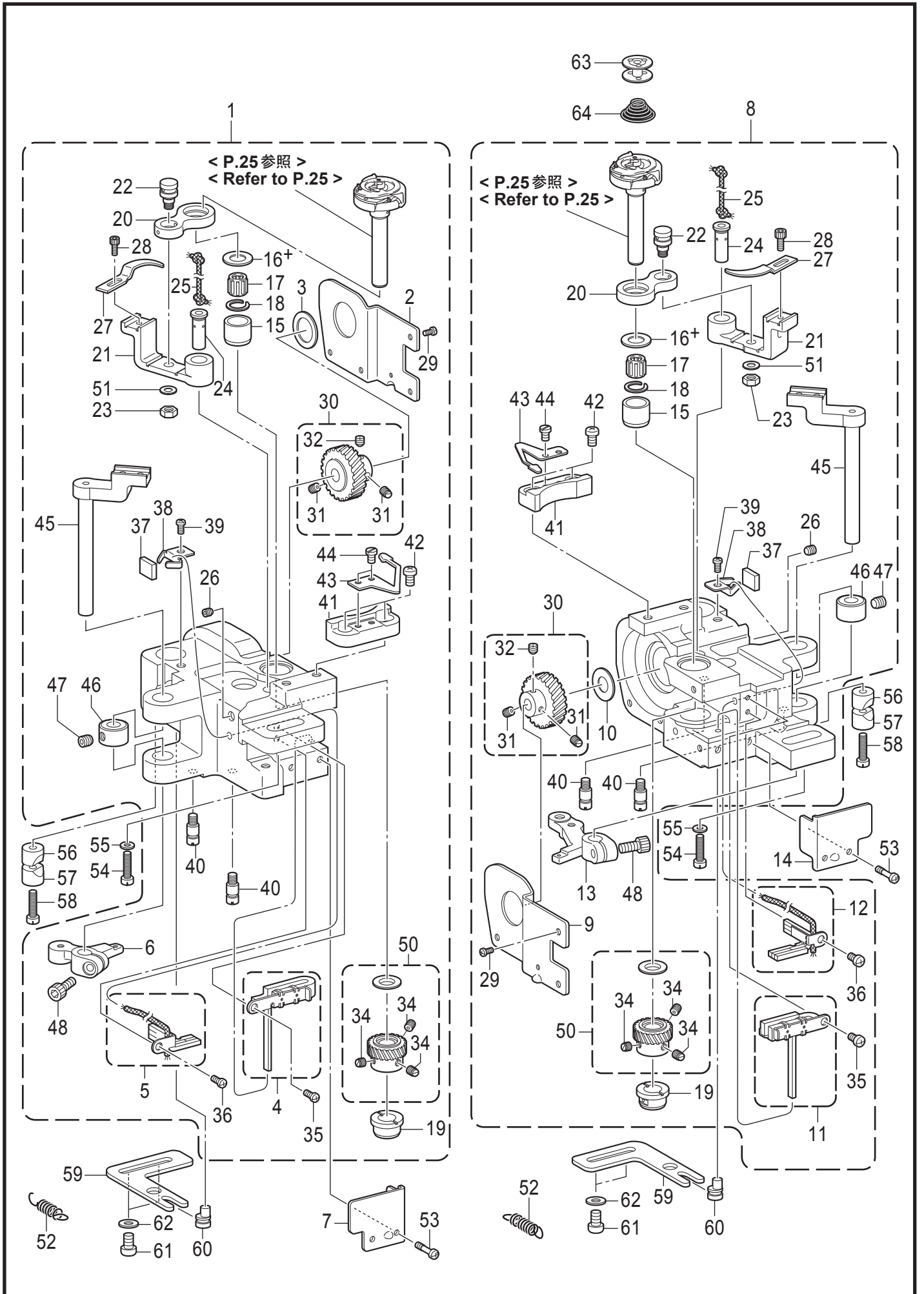

K1. かま関係 / Rotary hook mechanism

REF.NO	CODE	Q'TY	品名	NAME OF PARTS	RM
59	SA2567001	2	ハリスキチヨウセツイタ	NEEDLE UPPER ADJUSTING PLATE	
60	SA2568001	2	ハリスキチヨウセツジク	NEEDLE UPPER POSITIONING SHAFT	
61	062061016	4	ナベコ6X10	SCREW PAN M6X10	
62	025060136	4	ヒラザガネシヨウ6	WASHER PLAIN S 6	
63	S09285051	2	ボビン	BOBBIN	
64	S09286000	2	クウテンボウシバネ	ANTI-SPIN SPRING	

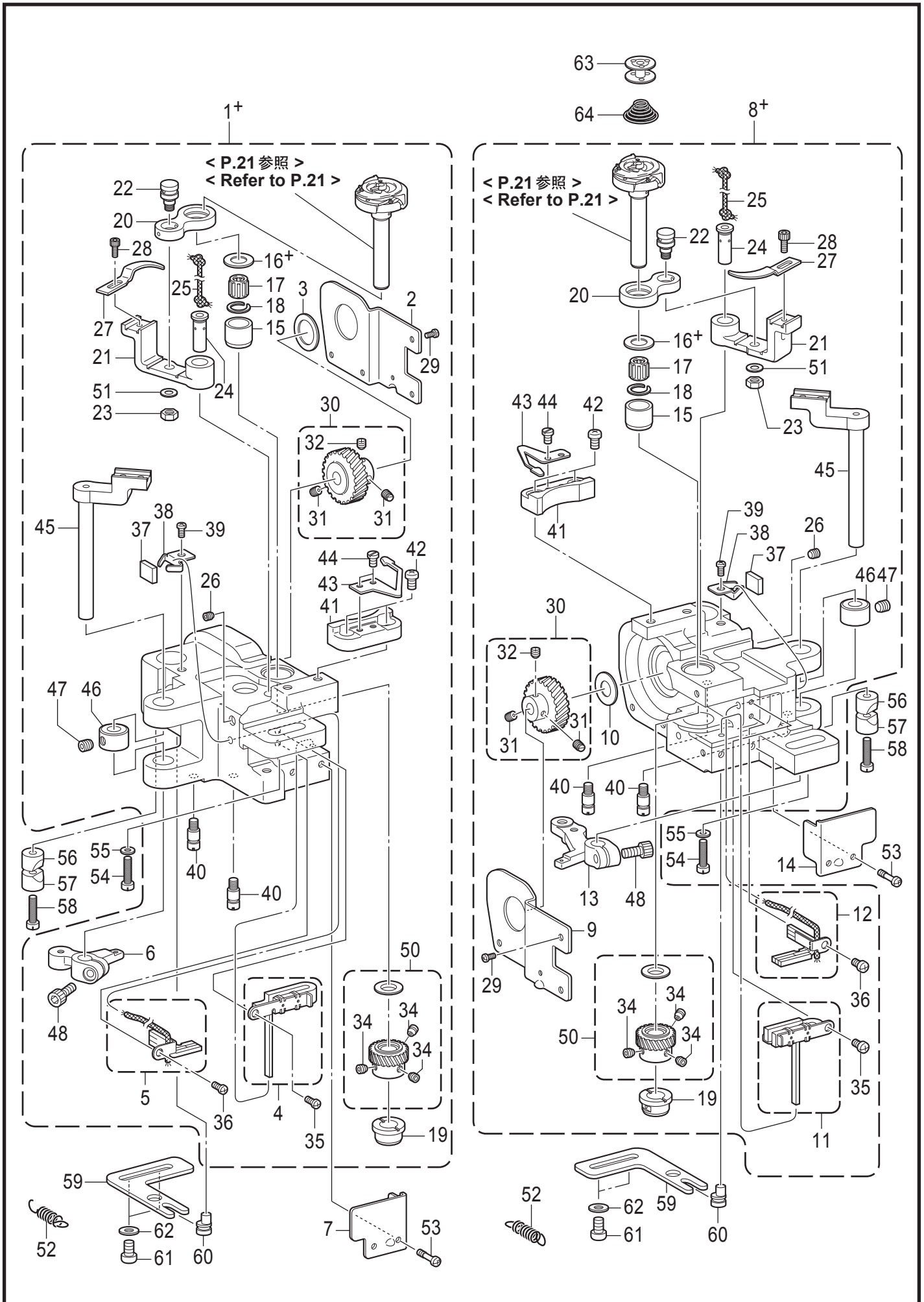

J1. かま関係 / Rotary hook mechanism

REF.NO	CODE	Q'TY	品名	NAME OF PARTS	RM
50	SA7868101	2	ピニオンセット B	PINION GEAR SET B	
51	SB2330001	2	ヒラザガネシヨウ4.76	WASHER PLAIN S SM4.76	
52	SA2826001	2	イトキリレバーバネ	SPRING, EXTENSION	
53	SA6417001	4	シメネジM4X12	SCREW M4X12	
54	SA2556001	2	シメネジM6X25	SCREW, M6X25	
55	115947101	2	ザガネ	WASHER PLAIN 6.35	
56	SA2722001	2	ピンチスリーブA	PINCH SLEEVE A	
57	SA2565001	2	ピンチスリーブB	PINCH SLEEVE B	
58	SA2556001	2	シメネジM6X25	SCREW, M6X25	
59	SA2567001	2	ハリスキチヨウセツイタ	NEEDLE UPPER ADJUSTING PLATE	
60	SA2568001	2	ハリスキチヨウセツジク	NEEDLE UPPER POSITIONING SHAFT	
61	062061016	4	ナベコ6X10	SCREW PAN M6X10	
62	025060136	4	ヒラザガネシヨウ6	WASHER PLAIN S 6	
63	S09285051	2	ボビン	BOBBIN	
64	S09286000	2	クウテンボウシバネ	ANTI-SPIN SPRING	