

100% MADE IN ITALY



1946

FP861A2

PNEUMATIC CUTTING UNIT

FP861A2. Professional pneumatic cutting unit for Textile & Technical Textile applications.



1946

WHAT'S NEW:

Central back-located air exhaust
New semi-automatic sharpening device
Teflon® coated aluminium base
Easy fixing structure for O.E.M. applications

TECHNICAL DETAILS:

- Blade diameter:** 86 mm (3.4"), with hard metal counterblade
- Blade equipped:** 86THSS, 8-edges, HSS steel
- Blade speed:** 900 r.p.m.*
- Cutting ability:** up to 25 mm (1")
- Power:** 400 W (at nominal air supply conditions*)
- Operating pressure:** 6 bar nominal* (± 1 bar) lubricated air supply
- Air consumption:** 9 l/sec*
- Net weight:** 1350 g
- Total weight (with packing box):** 3050 g
- Sound pressure:** 72 dBc (EN ISO 15744)*
- Vibration Level:** 1,36 m/sec² (ISO 8662)*
- Minimum brightness for working operations:** LUX 200
- Temperature range:** 0 – 55 C
- Umidity range:** 10 – 95% without condensate

*The reported data are collected at a pressure of 6 bar (ISO 2787: 1984), recommended operating pressure.

PNEUMATIC CUTTING UNIT FP861A2

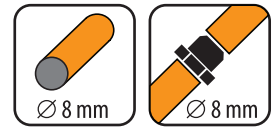

minimum recommended

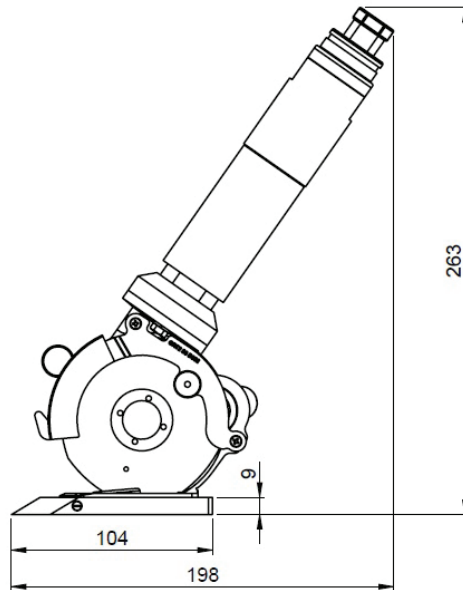

Dimension layout



Rasor recommend to use only dry air lubricated with special Rasor VG 5 pneumatic oil

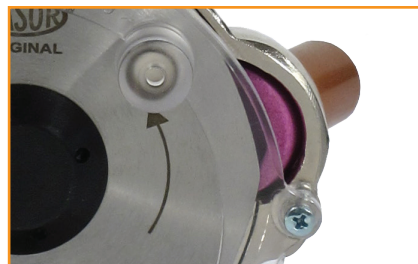

Sharpening device



BLADES AVAILABLE:

86PHSS, 86 mm 5-edges, HSS steel | **86THSS**, 86 mm 8-edges, HSS steel | **86PHSSTF**, 86 mm 5-edges, HSS steel Teflon® coated | **86THSSTF**, 86 mm 8-edges, HSS steel Teflon® coated | **86THSSTN**, 86 mm 8-edges, HSS steel Titanium coated | **86TMD**, 86 mm 8-edges, Carbide (Widia®)



FOLLOW US:



RASOR ELETTROMECCANICA SRL

Via Vincenzo Caldesi 6
20161 Milan · Italy
ph. +39 02 66 22 12 31
fax +39 02 66 22 12 93
info@rasor-cutters.com

www.rasor-cutters.com